

Datasheet M55

Coriolis Mass Flow Meter for Liquids and Gases



CORI-FLOW Coriolis Mass Flow Meter model M55

> Introduction

Bronkhorst Cori-Tech model M55 CORI-FLOW™ Mass Flow Meters (MFMs) are precise and compact instruments, based on the Coriolis measuring principle, designed to cover the needs of the low flow market. The MFMs offer “multi-range” functionality: factory calibrated ranges can be rescaled by the user, maintaining the original accuracy specs. The instruments are equipped with a robust IP65 weatherproof housing and are optionally available with ATEX approval for use in Zone 2 hazardous areas. The MFM contains a microprocessor based pc-board with signal and fieldbus conversion and a PID controller for optional mass flow control by means of a separately mounted control valve or pump. The mass flow is provided as analog signal or digitally via RS232 or optional fieldbus. The flow range and wetted materials are determined depending of the type of fluid and the process conditions of the application.

> Technical specifications

Flow sensor rates

Minimum full scale gas/liquid	: 20 kg/h
Nominal flow	: 500 kg/h
Maximum full scale	: 600 kg/h
Recommended min. flow	: 0,5 kg/h
Zero stability	: < 0,1 kg/h

Performance

Accuracy liquid	: 0,2% of rate, range 1...100%
Accuracy gas	: 0,5% of rate, range 1...100%
Repeatability	: 0,1% of rate (based on digital output)
Mounting position	: preferred mounting position on liquid service upside down

Mechanical parts

Material (wetted parts)	: stainless steel 316L or comparable
Process connections (welded)	: Compression type or face seal couplings
Ingress protection (housing)	: IP65 (weatherproof)
Leak integrity	: < 2 x 10 ⁻⁹ mbar l.s ⁻¹ He
Pressure rating	: 100 bar
Temperature range	: 0...70°C for standard version, (ambient + fluid) 0...120°C with remote electronics, 130°C ≤ 1 hour allowed for CIP

Electrical properties

Power supply	: +15...24 Vdc ±10% Max. ripple recommended: 50 mV tt
Power consumption	: approx. 80 mA at 15 Vdc
Analog output	: 0...5 (10) Vdc, min. load impedance > 2 kΩ; 0 (4)...20 mA (sourcing), max. load impedance < 375 Ω
Analog setpoint (for MFM + control valve/pump)	: 0...5 (10) Vdc, min. load impedance > 424 kΩ; 0 (4)...20 mA, load impedance ~250 Ω
Digital communication	: Standard RS232; Options: Profibus-DP®, DeviceNet™, Modbus-RTU, FLOW-BUS

Electrical connections

Analog/RS232	: male, 8-pin Amphenol for power, analog I/O and RS232
Profibus-DP	: bus: 5-pin M12 female; power: 8-pin DIN male
DeviceNet/Modbus/FLOW-BUS	: 5-pin M12 male

Although all specifications in this datasheet are believed to be accurate, the right is reserved to make changes without notice or obligation.

> Model number identification

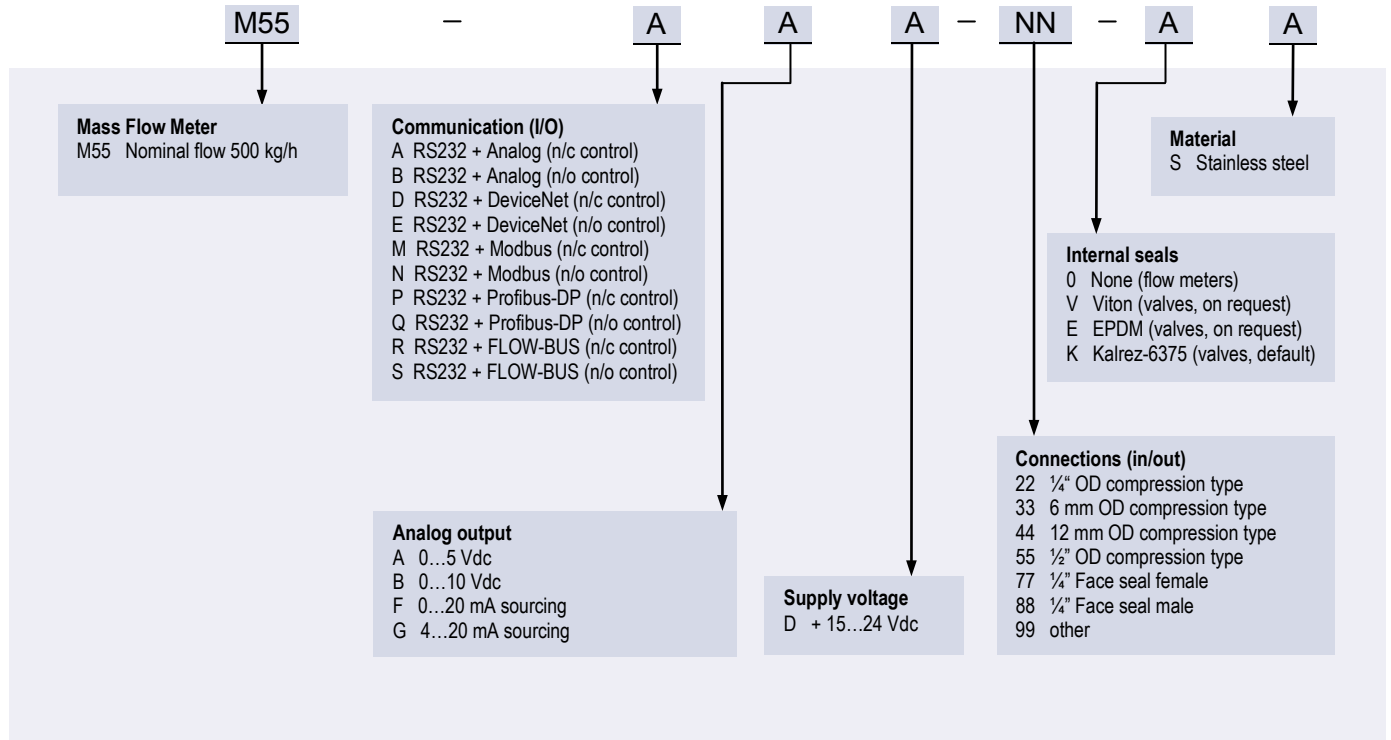

> Measuring principle

The **CORI-FLOW™** contains two parallel tube loops, forming part of an oscillating system. When a fluid flows through the tubes, Coriolis forces cause a variable phase shift between the loops, which is detected by sensors and fed into the integrally mounted pc-board. The resulting output signal is strictly proportional to the real mass flow rate..

No flow

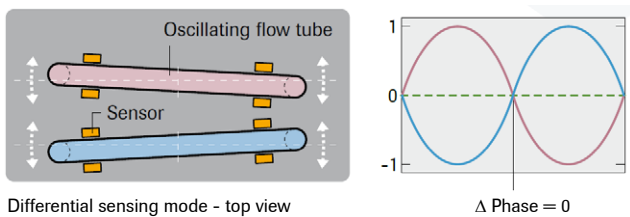

Flow

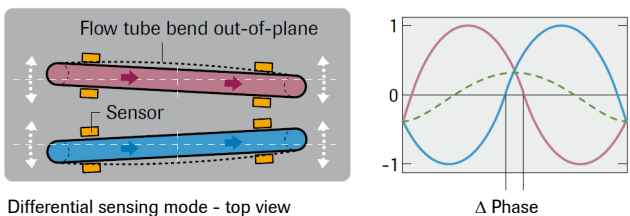

> State of the art digital design

CORI-FLOW™ series are equipped with a digital pc-board, offering high accuracy, excellent temperature stability and fast response. The basic digital pc-board contains all of the general functions needed for measurement and control. In addition to the standard RS232 output the instruments also offer analog I/O. Furthermore, an integrated interface board provides DeviceNet™, Profibus-DP®, Modbus-RTU or FLOW-BUS protocols.

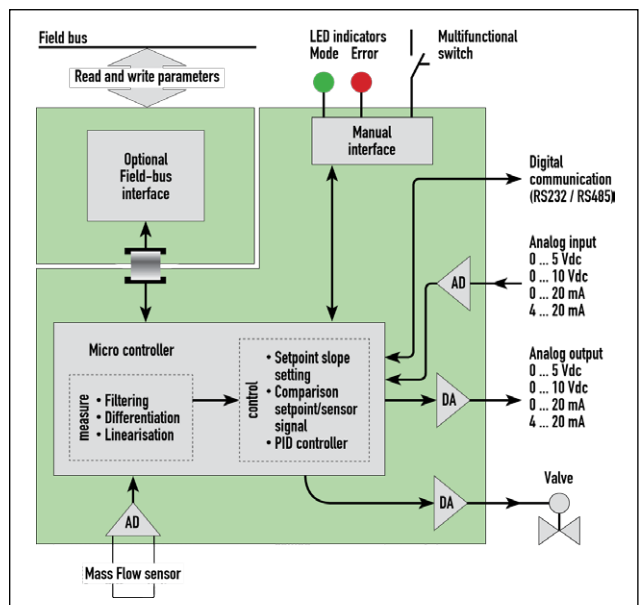

Functional scheme of the digital PC-board

> Dimensions (mm) and weight (kg)



Weight: 3,1 kg

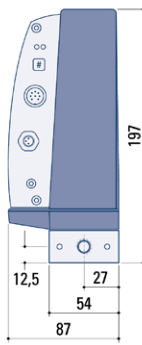





Table 1 (Z-values in mm)





Compression type	Size Z
adapter 1/4" OD	204
adapter 6 mm OD	204
adapter 12 mm OD	250
adapter 1/2" OD	250

Face-seal	Size Z
adapter 1/4" male	202
adapter 1/4" female	202
adapter 1/2" male	241

> Options and accessories

- Free software support for operation, monitoring, optimizing or to interface between digital instruments and windows software.	
- BRIGHT compact local Readout/Control module - E-5700 / E-7000 Power Supply	
- Interconnecting cables for power and analog/digital communication - PiPS Plug-in Power Supply	
- Impact protection cover for ATEX Zone 2 applications	

> Alternatives

- Model M54 CORI-FLOW™ Mass Flow Meter (flow rates from 0,2 upto 100 kg/h)	
- Model M15 mini CORI-FLOW™ Mass Flow Meter (flow rates from 0,2 upto 300 kg/h)	
- Model M55C01 / M55C11 / M55C51 / M55+F-011AI / M55+F-004AI / M55+F-004BI CORI-FLOW™ Mass Flow Controller (flow rates from 0,5 upto 600 kg/h)	
- Model M55 CORI-FLOW™ Mass Flow Meter with Pressure Actuated Valve for fluids such as ethylene, propylene, supercritical CO ₂ (flow rates from 0,5 upto 600 kg/h)	

Bronkhorst Cori-Tech B.V.

Nijverheidsstraat 2-6

7261AK Ruurlo The Netherlands

Tel. +31 573 458890 Fax. +31 842 292375

Email: info@bronkhorst-cori-tech.com

Internet: www.bronkhorst-cori-tech.com

